

# SANLI Hedge Trimmer SLP600D

Item No.	Part No.	Description
1-1	SLHT001	Edge guard
1-2	SLHT002	Blade fixing plate
1-3	SLHT003	Blade
1-4	SLHT004	Blade guard
1-5	SLHT005	Protective handle
1-6	SLHT006	Parking switch assembly
1-7	SLHT007	Throttle rope 60
1-8	SLHT008	Lock throttle handle
1-9	SLHT009	Throttle control handle

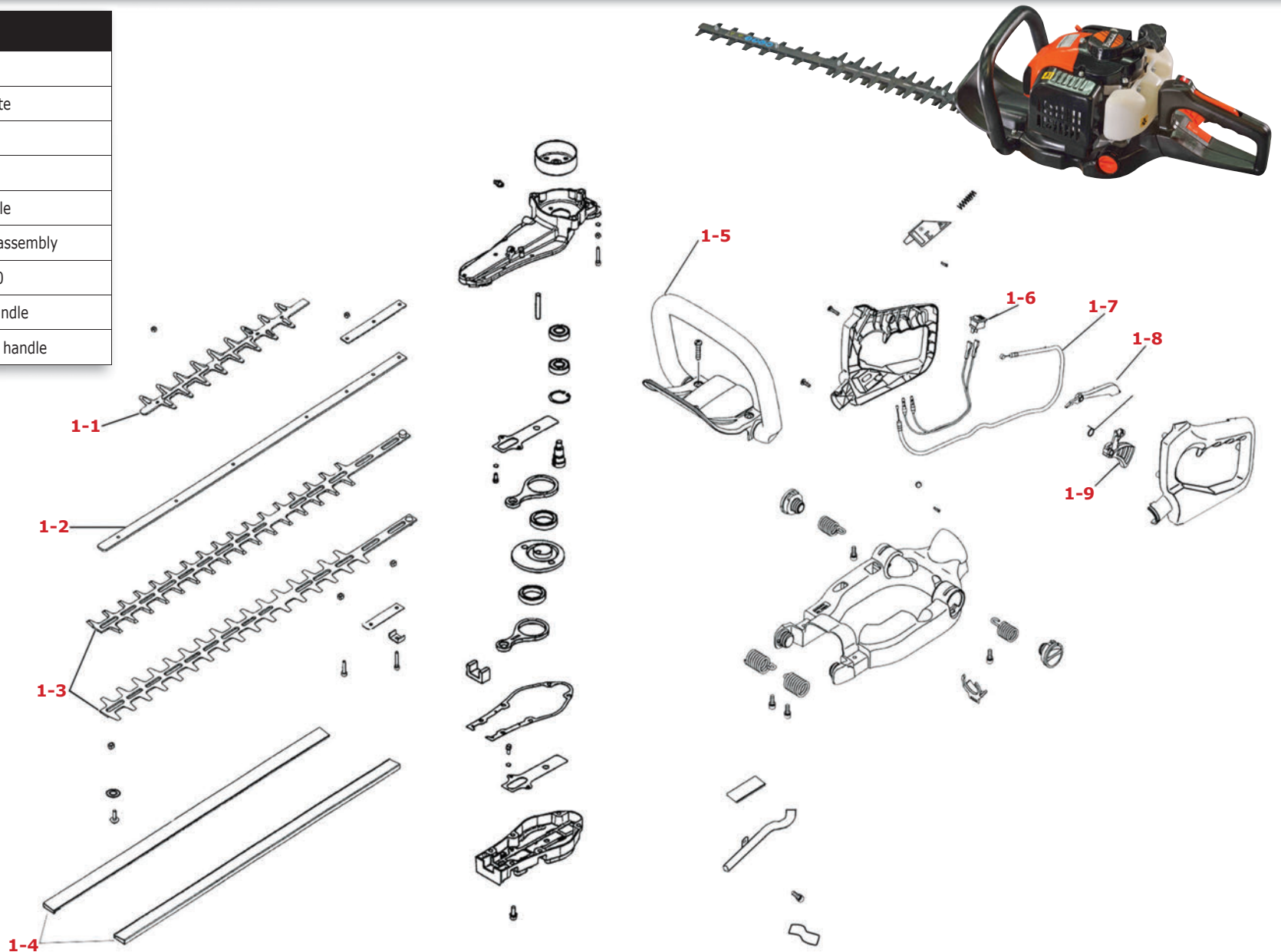

# SANLI Hedge Trimmer SLP600D

Item No.	Part No.	Description
<b>Engine</b>		
2-1	SLHT010	Cylinder cover
2-2	SLHT011	Cylinder block
2-3	SLHT012	Cylinder block gasket
2-4	SLHT013	Bearing
2-5	SLHT014	oil seal
2-6	SLHT015	Starting dial assembly
2-7	SLHT016	Starter assembly
2-8	SLHT017	Muffler cover (aromatic nylon)
2-9	SLHT018	Muffler assembly (with catalyst)
2-10	SLHT019	Carburettor pad E1001 8412A
2-11	SLHT020	Carburettor
2-12	SLHT021	Air filter bottom shell pad E1001 8411A
2-13	SLHT022	Choke handle
2-14	SLHT023	Inner cover
2-15	SLHT024	Air filter element

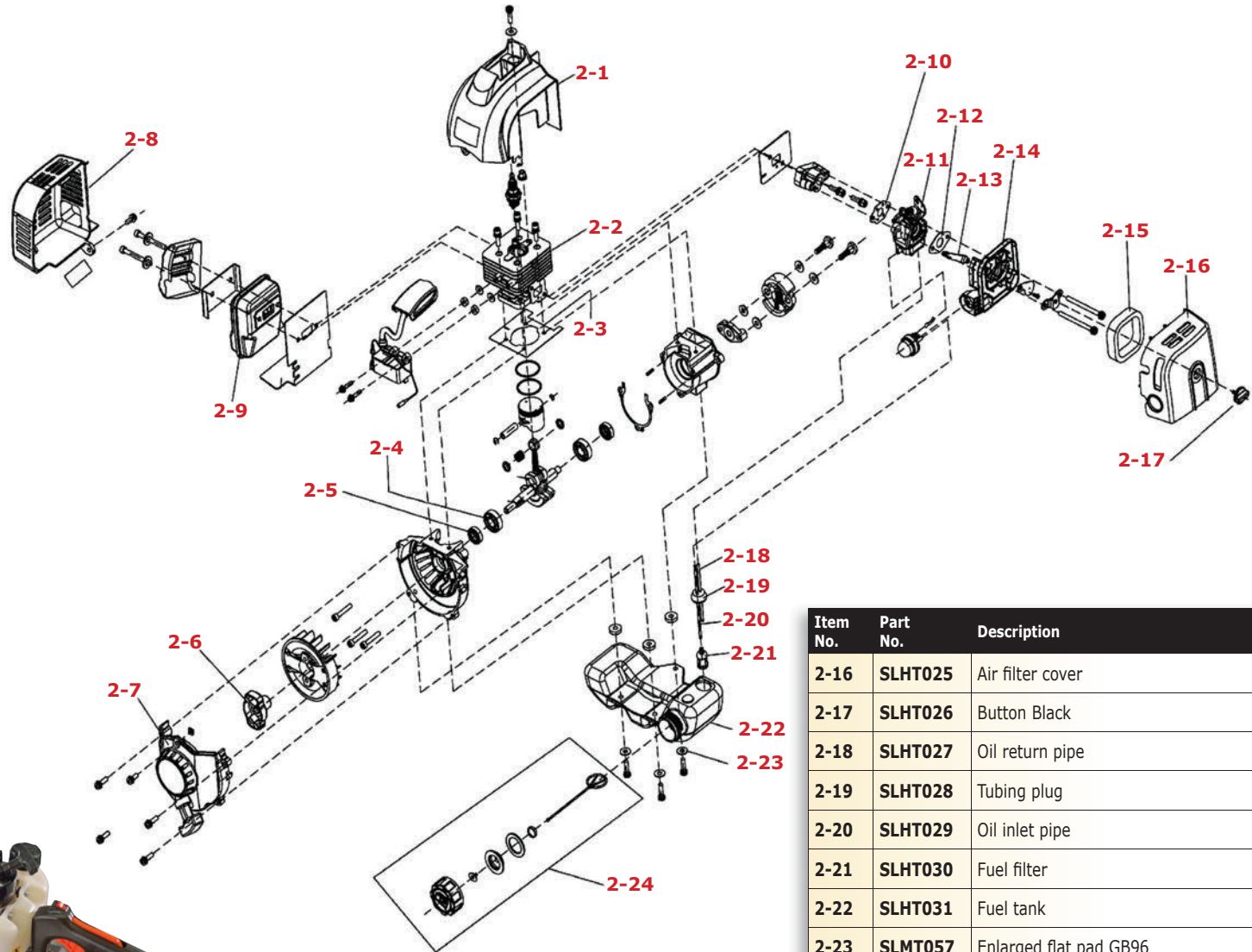

Item No.	Part No.	Description
2-16	SLHT025	Air filter cover
2-17	SLHT026	Button Black
2-18	SLHT027	Oil return pipe
2-19	SLHT028	Tubing plug
2-20	SLHT029	Oil inlet pipe
2-21	SLHT030	Fuel filter
2-22	SLHT031	Fuel tank
2-23	SLMT057	Enlarged flat pad GB96
2-24	SLHT032	Fuel tank cap assembly

